

# 中華メディアプレーヤー

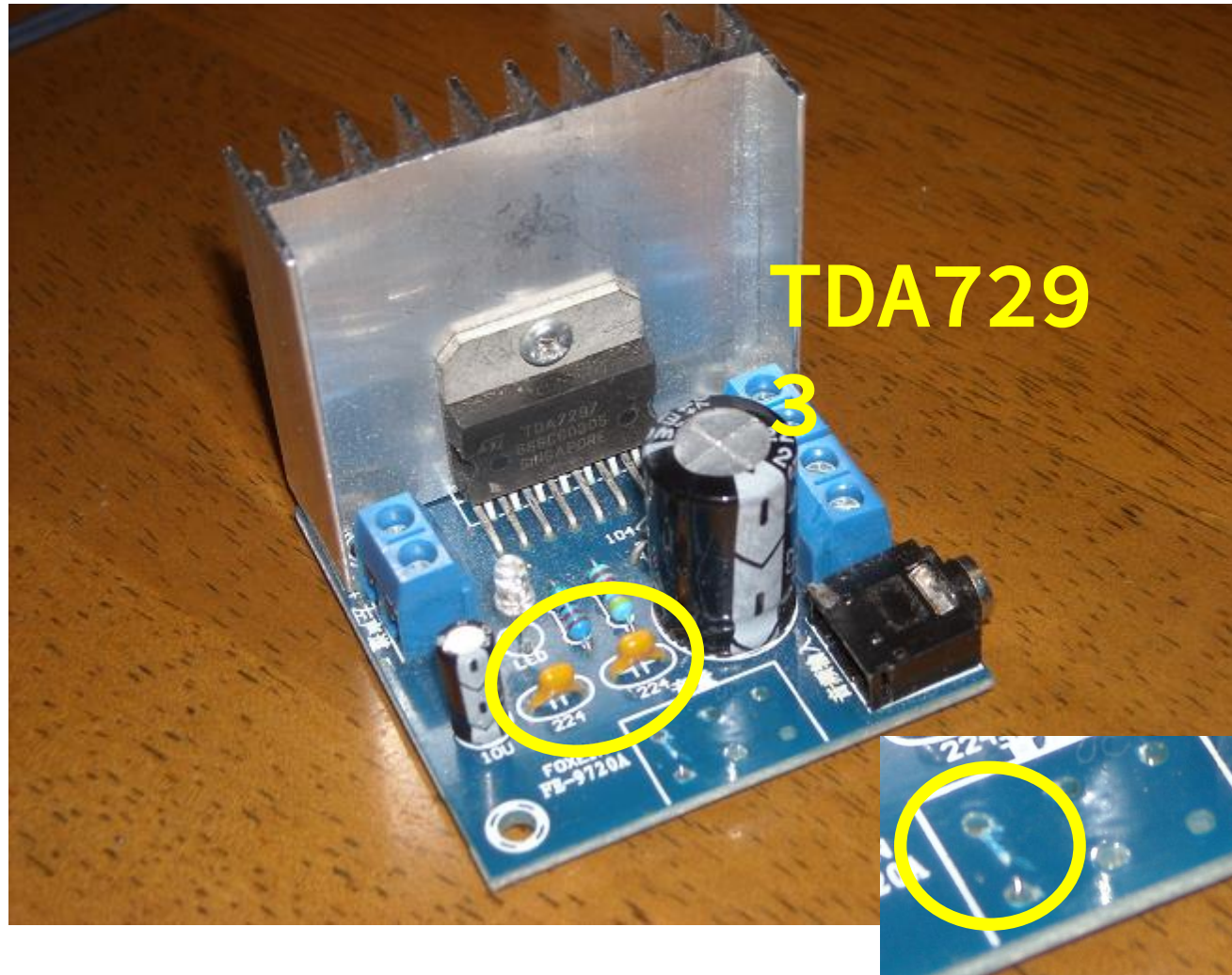

# 中華メディアプレーヤー

アンプ 2個 295円



MDPlayerMini 3個

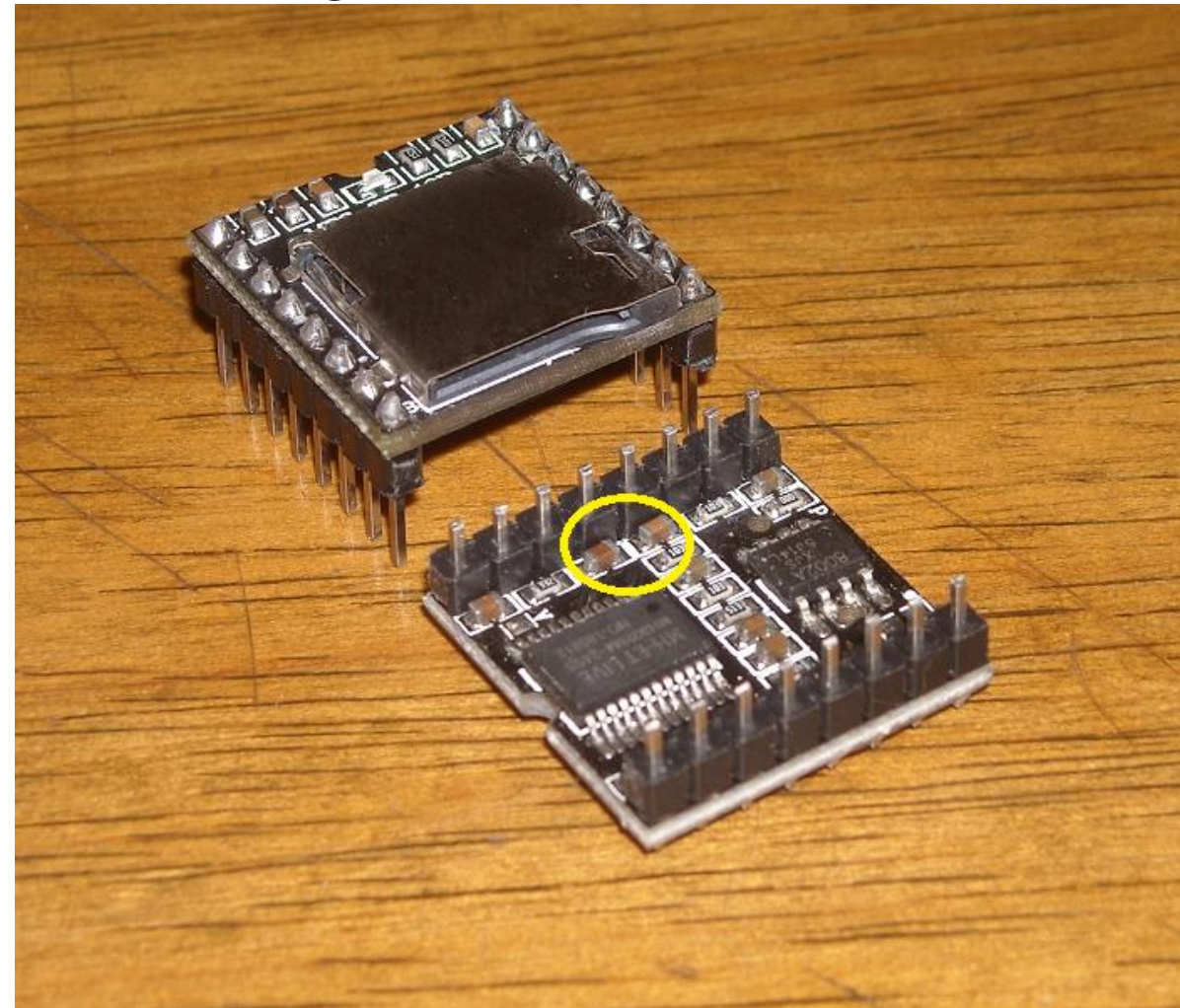

Phono in

Aux in

Phono out

DC 12V

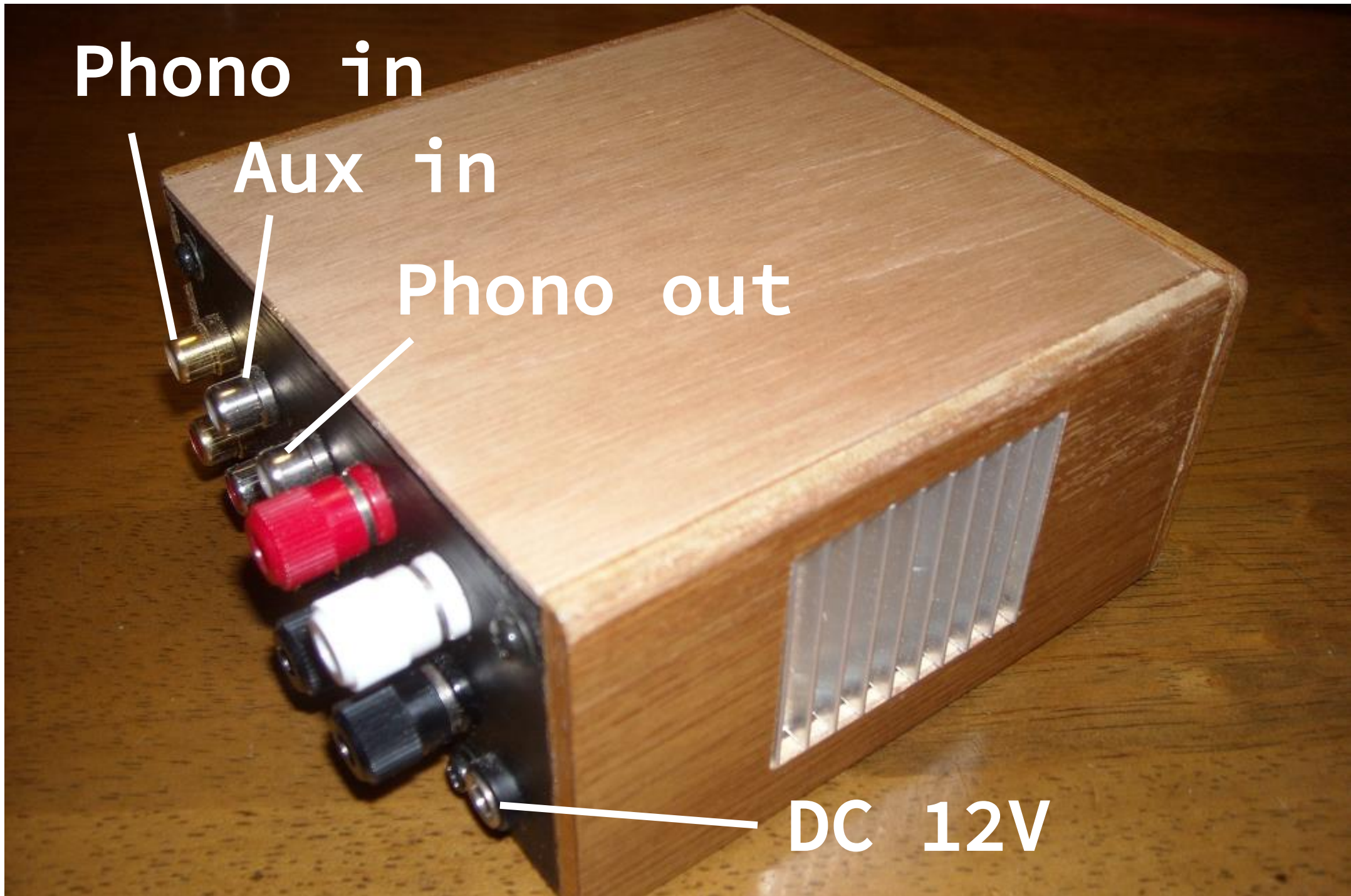

# DFPlayer Mini

## 1. Summary

### 1.1 .Brief Instruction

DFPlayer Mini module is a serial MP3 module provides the perfect integrated MP3, WMV hardware decoding. While the software supports TF card driver, supports FAT16, FAT32 file system. Through simple serial commands to specify music playing, as well as how to play music and other functions, without the cumbersome underlying operating, easy to use, stable and reliable are the most important features of this module.

### 1.2 .Features

- Support Mp3 and WMV decoding
- Support sampling rate of 8KHz,11.025KHz,12KHz,16KHz,22.05KHz,24KHz,32KHz,44.1KHz,48KHz
- 24-bit DAC output, dynamic range support 90dB, SNR supports 85dB
- Supports FAT16, FAT32 file system, maximum support 32GB TF card
- A variety of control modes, serial mode, AD key control mode
- The broadcast language spots feature, you can pause the background music being played
- Built-in 3W amplifier
- The audio data is sorted by folder; supports up to 100 folders, each folder can be assigned to 1000 songs
- 30 levels volume adjustable, 10 levels EQ adjustable.

### 3.5. Key Ports

We use the AD module keys, instead of the traditional method of matrix keyboard connection, it is to take advantage of increasingly powerful MCU AD functionality, Our module default configuration 2 AD port, 20 key resistance distribution, if used in strong electromagnetic interference or strong inductive, capacitive load of the occasion, please refer to our "Notes."

1).Refer diagram

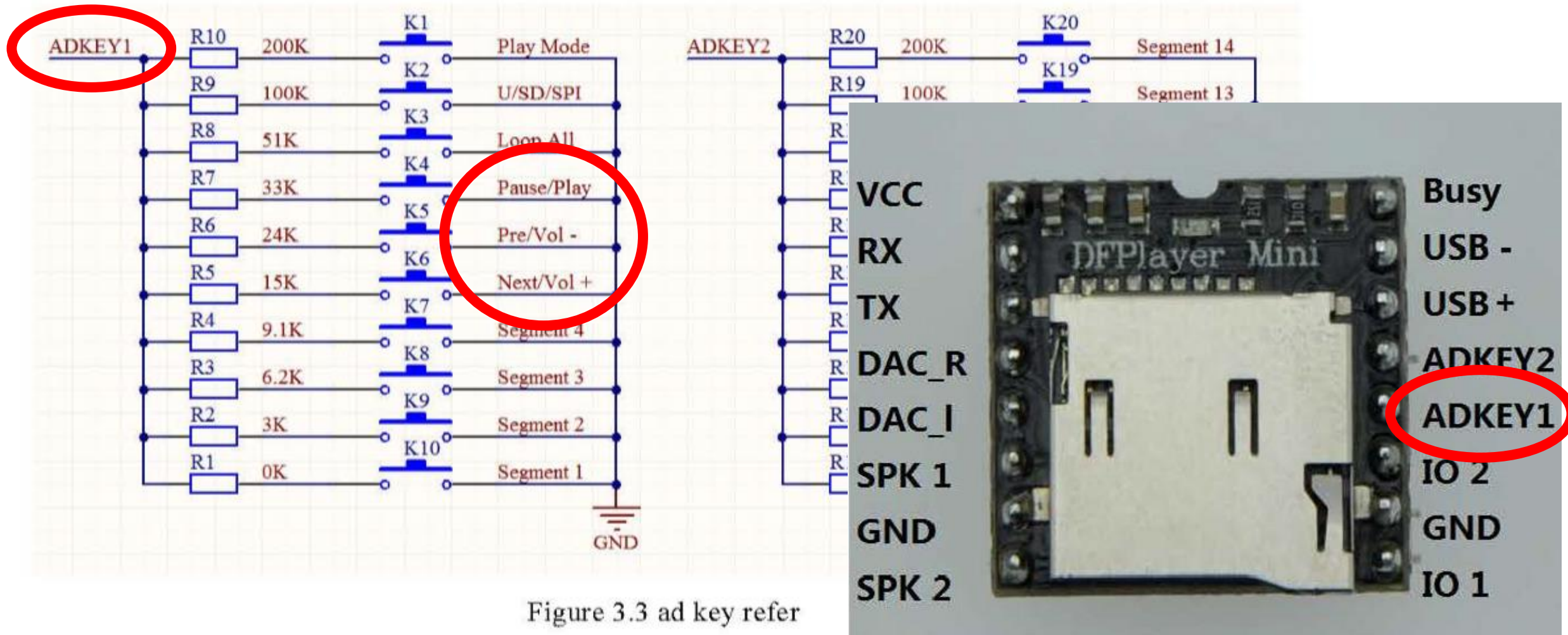

# DFPlayer Mini



# Specifications

電源 : 12 V

Wav : 48 kHz / 16 bit まで

中華パワーアンプ (TDA7293) : 15W×2

Phonoイコライザ (OpAmp×1) 付き